

**MARINER SL-I**

# SINGLE SLIDING DOOR

BOUNTY MARINE, INC. 11135 S.W. INDUSTRIAL WAY TUALATIN, OR. 97062 (503)692-4070

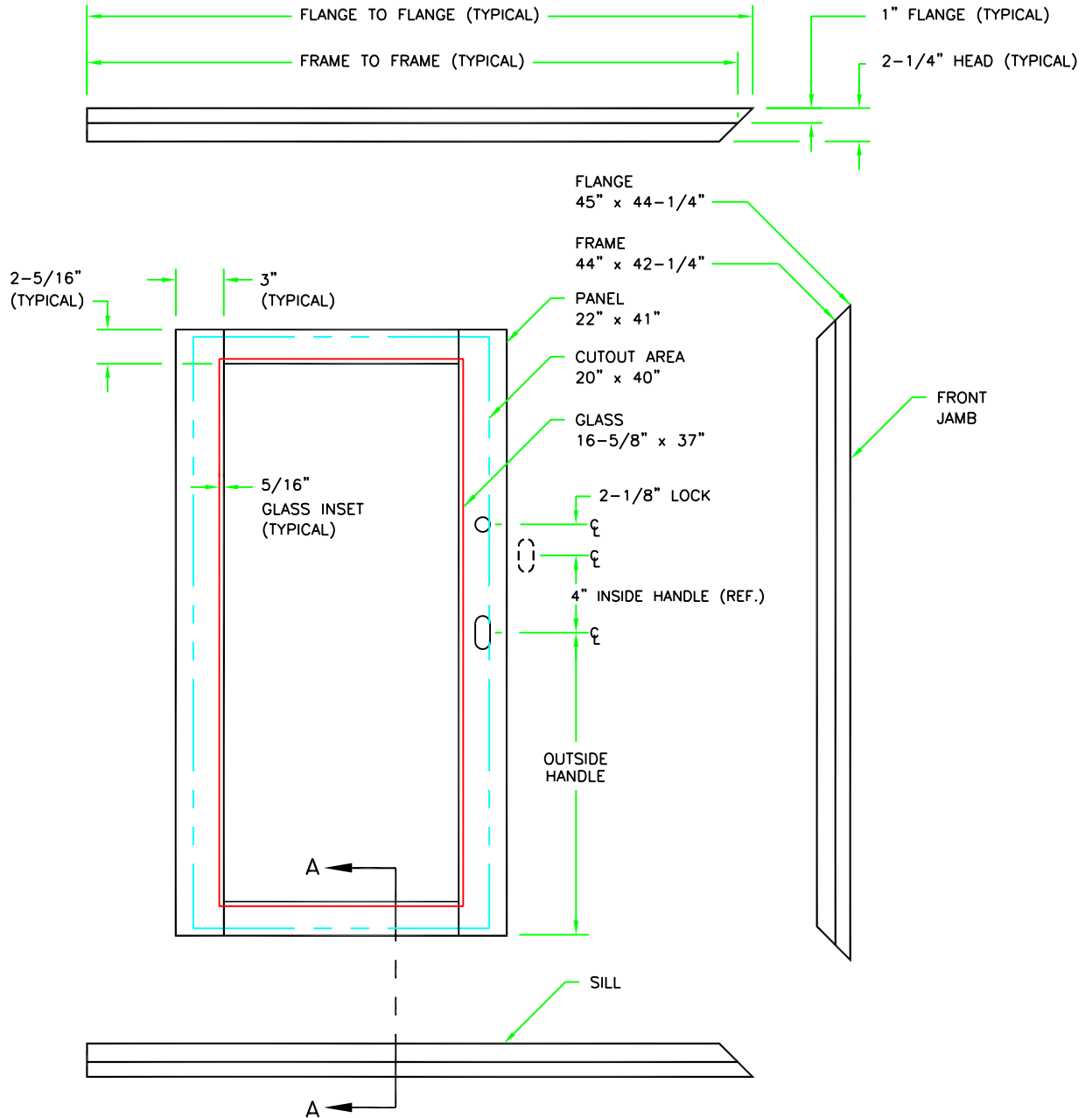
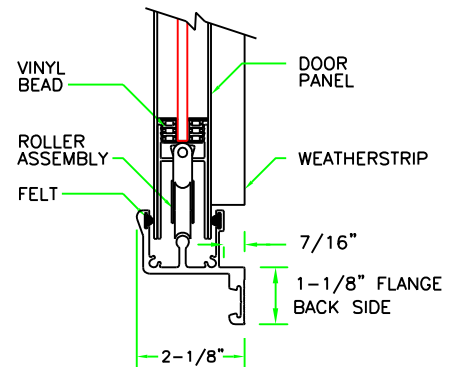

ILLUSTRATION VIEWED FROM OUTSIDE.  
BASED ON A CUTOUT SIZE OF 20" X 40".

**CALCULATIONS:**

CUTOUT WIDTH      x 2 + 4    = NET FRAME WIDTH  
 CUTOUT WIDTH      + 2"       = PANEL WIDTH  
 PANEL WIDTH       - 5-3/8"   = GLASS WIDTH

CUTOUT HEIGHT    + 2-1/4"   = NET FRAME HEIGHT  
 NET FRAME HEIGHT - 1-1/4"   = PANEL HEIGHT  
 PANEL HEIGHT     - 4"       = GLASS HEIGHT



VIEW A  
(TYPICAL FOR SILL AND HEAD)